

# 1500 GALLON GREASE INTERCEPTOR

## STANDARD FEATURES:

- 5000 PSI CONCRETE
- GRADE 60 REINFORCING
- 8" TRAFFIC BEARING LID
- AASHTO H-20 RATED
- 4" WALLS AND FLOOR
- 2 COMPARTMENTS STANDARD

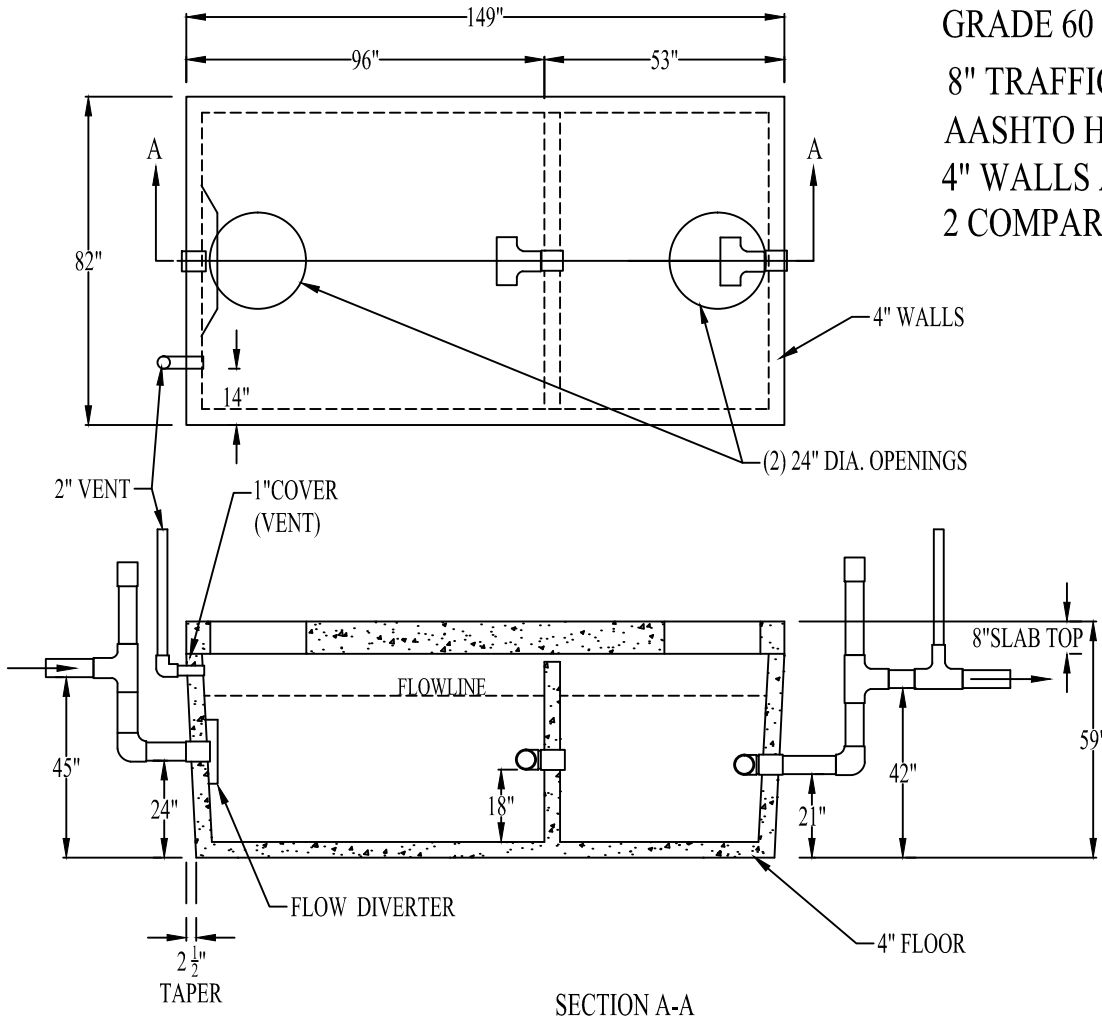

## NOTES:

- ALLOW FOR MANHOLE AND COVER IN TOTAL HEIGHT.
- STANDARD INLET/OUTLET FITTINGS ARE 4" BOOT (6" AVAILABLE)



**CAPITAL PRECAST, INC.**  
 6905 SOUTH OLD BASTROP HWY  
 SAN MARCOS, TEXAS 78666  
 PH. (830) 606-6200

FOR		1500 Grease Interceptor	
JOB			
DRAWN	DK	DATE	11/21/17
		Rev. No.	05/17/18
			07/30/19 03/24/20
FILE	RemovableDisk(H:)/1500GI.dwg		