

# 6'x9' Meter Vault with 36"x36" H2O Aluminum Lid

## (per City of Austin Specifications)

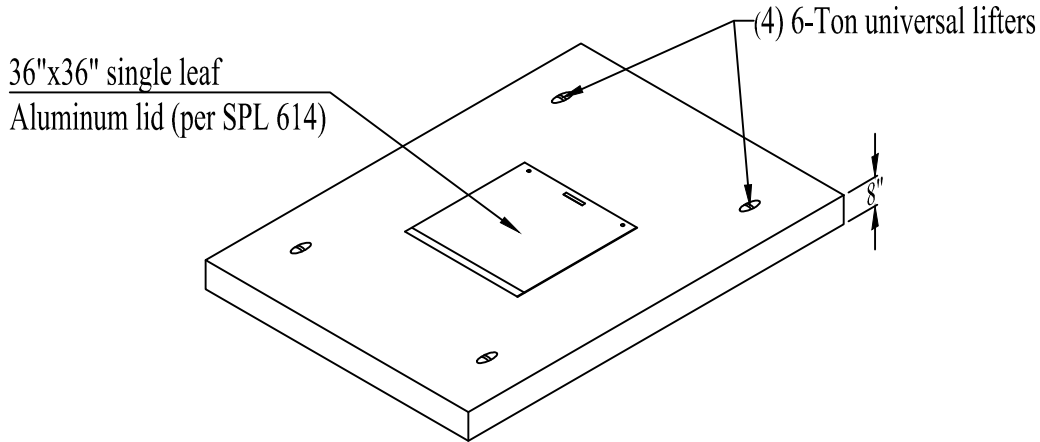

### Bottom Section NO FLOOR

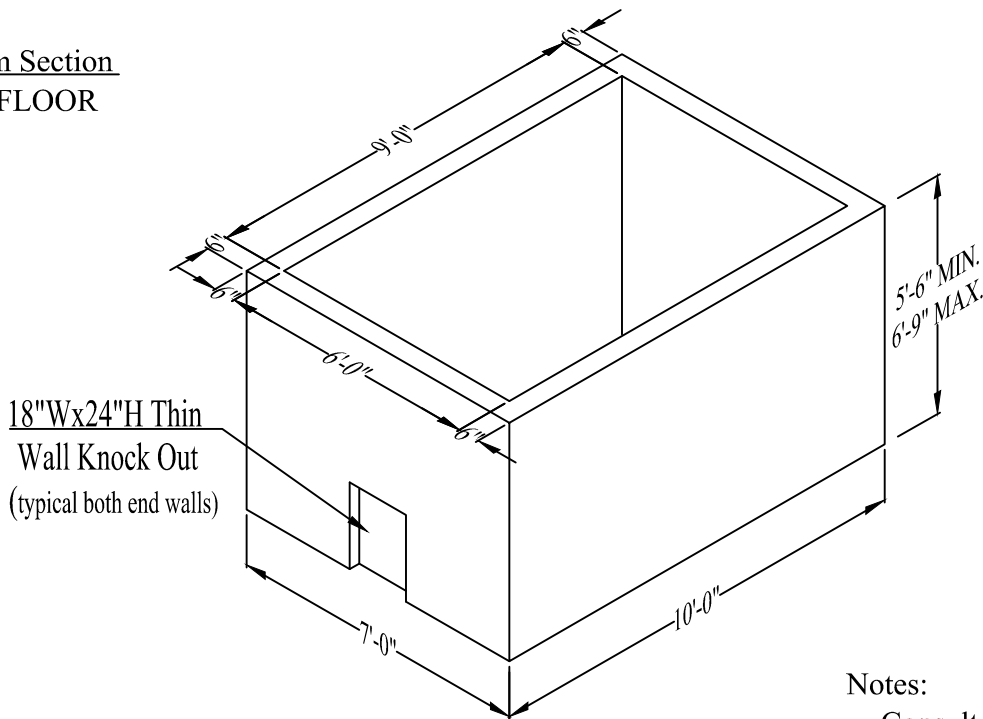

Approximate weight  
of bottom: 14,500 lbs  
at 6.0' high

#### GENERAL NOTES:

- All concrete to have 28 day compressive strength of 5000 psi.
- Reinforcing steel shall comply with ASTM A615 grade 60.
- Bar bending and placement shall comply with latest ACI standards.
- Design based on AASHTO HS 20-44 loading.

#### Notes:

- Consult manufacturer before handling
- Typical Applications:
  - City of Austin 3", 4", and 6" Compound & Turbine meters (SPL # 298)



CAPITAL PRECAST, INC.

6905 SOUTH OLD BASTROP HWY  
SAN MARCOS, TEXAS 78666  
PH. (830) 606-6200

FOR 6'x9' Meter Vault - Austin

JOB

DRAWN

DK

DATE

07/22/16

Rev. No.

SHEET

FILE

Removable Disk(G:)/6x9AustinMeterVault.dwg

1 OF 1