

10' City of San Marcos Curb Inlet

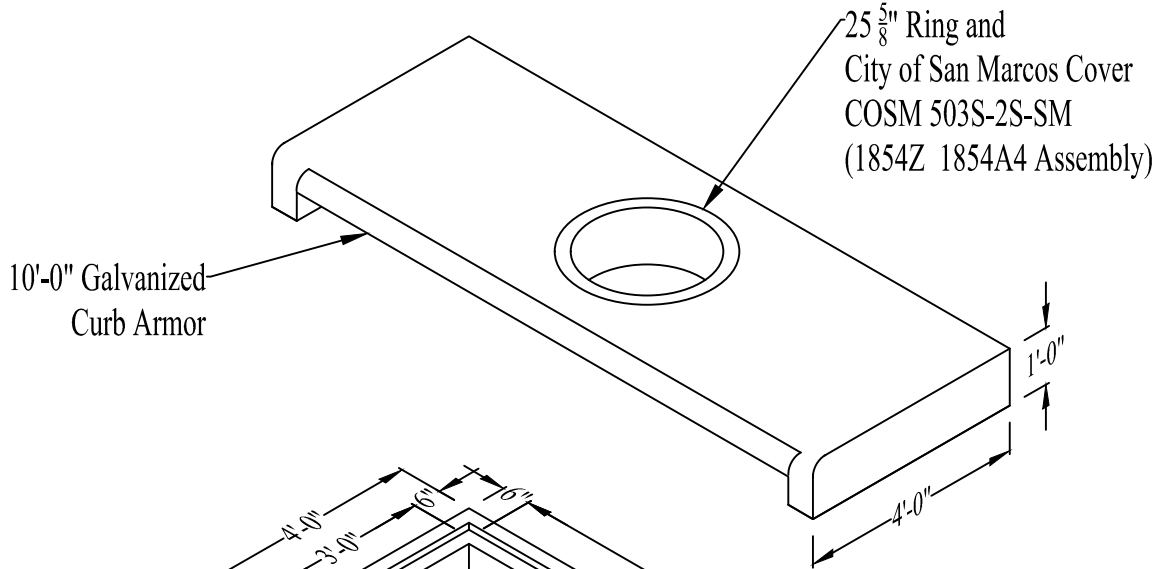

10'-0" Galvanized
Curb Armor

25 $\frac{5}{8}$ " Ring and
City of San Marcos Cover
COSM 503S-2S-SM
(1854Z 1854A4 Assembly)

Drill 6" deep holes (5/8" dia.)
at 12" O.C. on 3'-6" and 4'-0"
bases.
Holes shall be drilled in the field
per the direction of the City
Inspector on 3'-0" bases.

30" dia. TWKO's on front and
rear of 10'-0" inlets.
36"W x 30"H TWKO's on both
end walls of 10'-0" inlets.

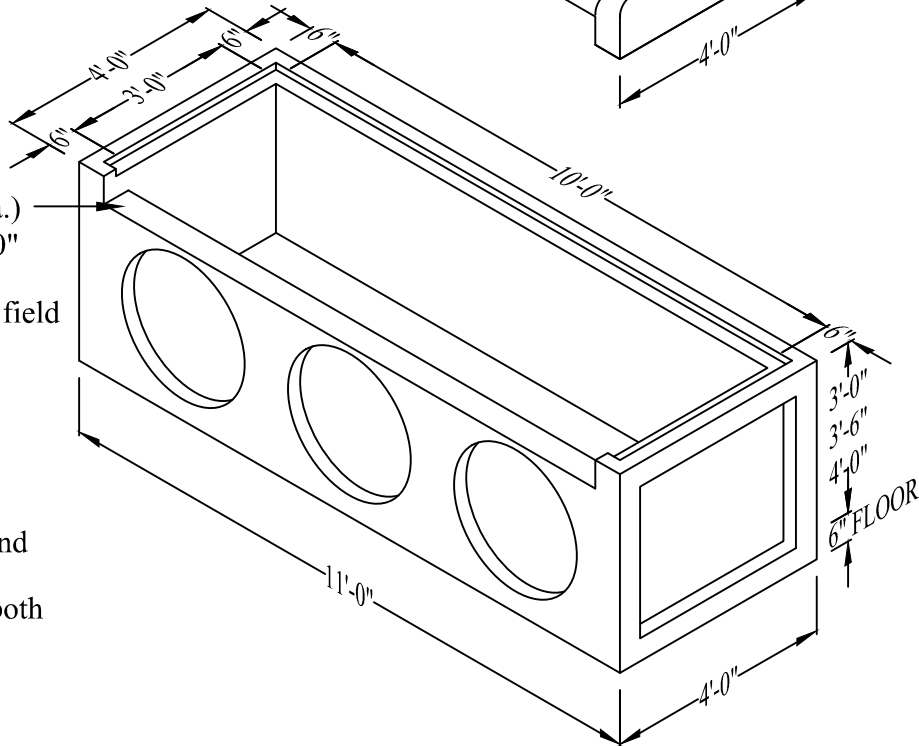

GENERAL NOTES:

All concrete to have 28 day compressive strength of 5,000psi.
Reinforcing steel shall comply with ASTM A615 Grade 60.
Bar bending and placement shall comply with latest ACI standards.
Design based on AASHTO HS 20 loading.

Consult manufacturer before handling.



CAPITAL PRECAST, INC.

6905 SOUTH OLD BASTROP HWY
SAN MARCOS, TEXAS 78666
PH. (830) 606-6200

FOR 10' City of San Marcos Curb Inlet

JOB

DRAWN	DK	DATE	07/31/19	Rev. No.
-------	----	------	----------	----------

FILE	RemovableDisk(G:)/10City of SanMarcosC.I.dwg
------	--